



Coming Soon



DMU30

High Performance MEMS Inertial Measurement Unit (HPIMU)



Description

DMU30 is the first of a new family of High Performance MEMS IMUs (HPIMU) incorporating Silicon Sensing's tried and tested precision VSG3Q^{MAX} high-Q inductive and VSG5 low-noise PZT resonating ring gyroscopes and capacitive accelerometers.

DMU30 is a six-degree-of-freedom inertial measurement unit providing precise 3-axis outputs of angular rate and acceleration, delta angle and velocity, and temperature, at 200Hz. It uses a unique Multi-MEMS architecture to blend the inputs from dual independent MEMS sensing elements per axis to achieve benchmark all-MEMS inertial performance across the duty cycle.

DMU30 represents a realistic, alternative to established FOG/RLG based IMUs due to its exceptional bias stability and low noise characteristics, yet it is comparatively compact, lightweight and offers low cost of ownership.

Designed specifically to meet the growing demand from high-end commercial and industrial market applications for a 'tactical' grade non-ITAR IMU, DMU30 utilises Silicon Sensing's class leading MEMS inertial sensors integrated and calibrated using an in-house state-of-the-art test facility.

Key features

- Precision 6-DOF MEMS Inertial Measurement Unit
- Silicon Sensing's latest VSG3Q^{MAX} inductive gyro and capacitive MEMS accelerometer
- Excellent Bias Instability and Random Walk
Angular - 0.2°/hr, 0.02°/√hr Linear - 30µg, 0.05m/s/√hr
- Non-ITAR
- Compact and lightweight - 68.5 x 61.5 x 65.5H (mm), 330g
- Internal power conditioning to accept 4.75V to 36V input voltage
- RS422 interfaces
- -40°C to +85°C operating temperature range
- Sealed aluminium housing
- RoHS compliant
- In-house manufacture from MEMS fabrication to IMU calibration
- Evaluation kit and integration resources available
- First class customer technical support
- Future developments and expansion capability, e.g. magnetometer, barometer, GPS

Applications

- Hydrographic surveying
- Airborne survey and mapping
- INS (Inertial Navigation Systems)
- AHRS (Attitude and Heading Reference System)
- GPS drop-out aiding
- Maritime guidance and control
- GNSS (Global Navigation Satellite System)
- Autonomous vehicle control and ROVs
- Machine control
- MEMS alternative to FOG/RLG IMUs

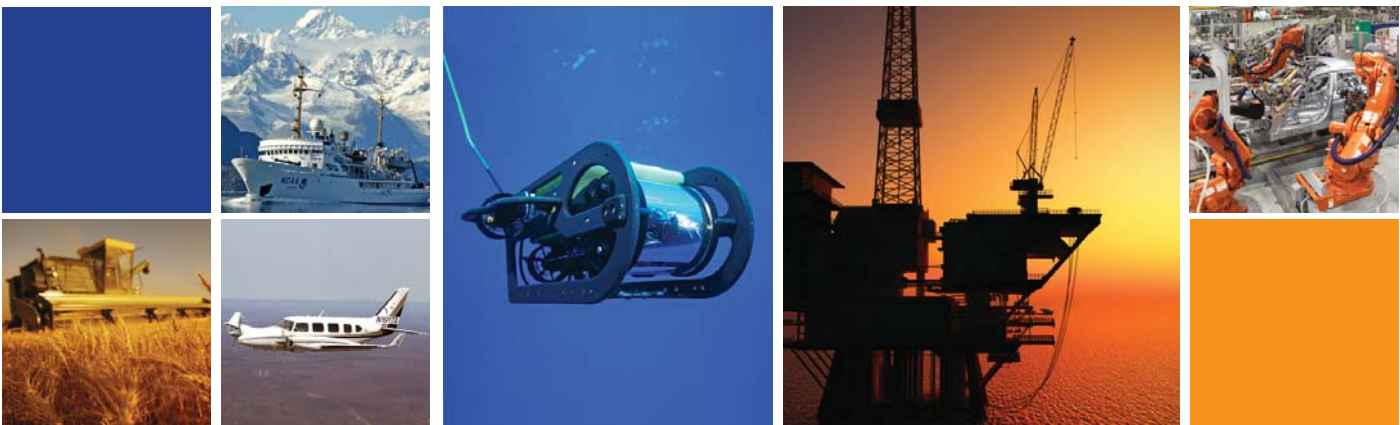

DMU30

High Performance MEMS
Inertial Measurement Unit (HPIMU)



DMU30

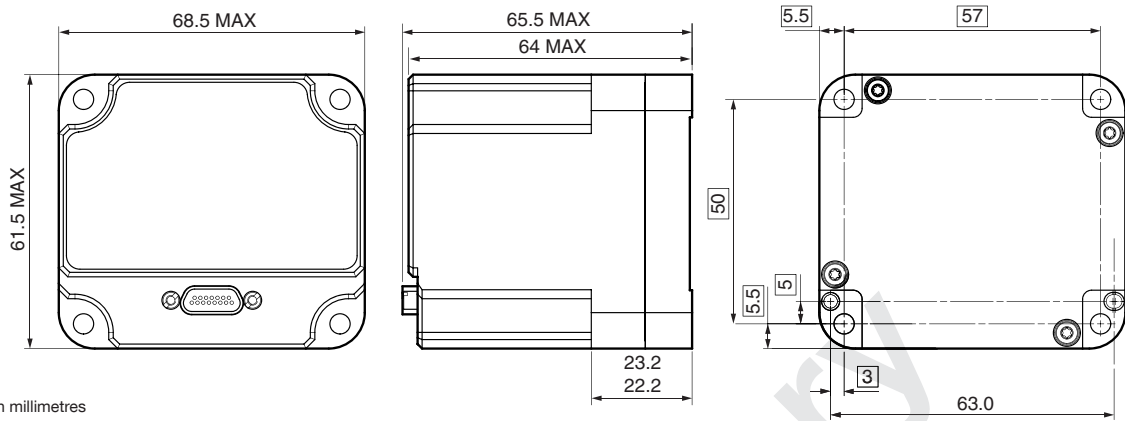

All dimensions in millimetres

Typical Data

Parameter	Specification
Gyroscope Properties	
Dynamic range	$\pm 490^\circ/\text{s}$
Scale factor over temp ($\pm 200^\circ/\text{s}$)	$\pm 100\text{ppm}$
SF non-linearity ($\pm 200^\circ/\text{s}$)	$\pm 100\text{ppm}$
Bias instability	$< 0.2^\circ/\text{h}$
Random walk	$< 0.02^\circ/\sqrt{\text{h}}$
Bias over temp	$\pm 15^\circ/\text{h}$
Noise (rms to 100Hz)	$0.15^\circ/\text{s}$
Accelerometer Properties	
Dynamic range	$\pm 10\text{g}$
Scale factor over temp ($\pm 1\text{g}$)	$\pm 100\text{ppm}$
SF non-linearity ($\pm 10\text{g}$)	$\pm 2000\text{ppm}$
Bias instability	$< 0.03\text{mg}$
Random walk	$< 0.05\text{m/s}/\sqrt{\text{h}}$
Bias over temp	$\pm 1.5\text{mg}$
Noise (rms to 100Hz)	1.00mg
Cross Axis Sensitivity	
Over temperature	$\pm 0.20\%$
IMU Temperature Sensor Properties	
Range	-45 to 100°C
Accuracy at temperature	$\pm 3.0^\circ\text{C}$
IMU Properties	
Operating temperature	-40 to 85°C
Start-up-time (full performance)	$< 1.2\text{s}$ ($< 5\text{s}$)
Power	$< 3\text{W}$
Supply voltage	4.75 to 36V
Mass	330g



DMU30 EVK Evaluation Kit
(P/N DMU30-00-0500)

For full technical datasheets please visit:
www.siliconsensing.com

Silicon Sensing Systems Limited
Clifford Road, Southway,
Plymouth, Devon
PL6 6DE United Kingdom

T +44 (0)1752 723330
F +44 (0)1752 723331
E sales@siliconsensing.com
W siliconsensing.com

Silicon Sensing Systems Japan Limited
1-10 Fuso-Cho,
Amagasaki,
Hyogo 6600891, Japan

T +81 (0)6 6489 5868
F +81 (0)6 6489 5919
E sssj@spp.co.jp
W siliconsensing.com

Specification subject to change without notice.

© Copyright 2016
Silicon Sensing Systems Limited
All rights reserved. Printed in England 09/16

DMU30-00-0100-131 Rev 3
DCR No. 710011677