

SiRRS01

Angular Rate Sensor



The SiRRS01 angular rate sensor has evolved from the highly successful Vibrating Structure Gyroscope developed by BAE Systems, which has been in service since 1990.

This MEMS implementation of our VSG technology, offers continued advancement in miniaturisation and reliability.

Designed to provide high performance operation under harsh environmental conditions, the SiRRS01 is ideally suited for a wide range of applications.

The SiRRS01 is underpinned by Silicon Sensing's commitment to the technical backup and long term support necessary for major procurement programmes.

Key Features

- Micro machined silicon (MEMS) technology
- Affordable, robust and rugged design
- Hermetically sealed
- Excellent shock and vibration performance
- Long life and exceptional reliability
- Comprehensive Built In Test (BIT)
- Integrated temperature sensor
- Compact and lightweight
- Low power consumption
- Sensor modelling data available



SiRRS01

Angular Rate Sensor

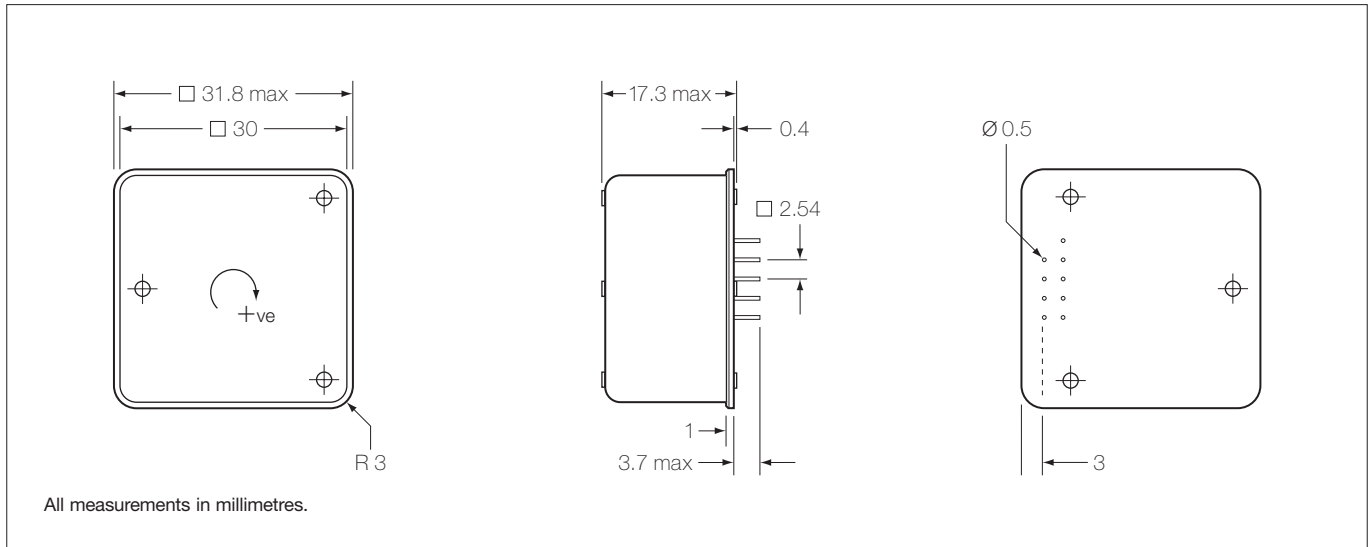

Specification

Specification (Typical Data)	RRS01-01
Angular Rate Range	$\pm 110^\circ/\text{s}$ (other ranges available - see table)
Scale Factor	
Nominal	18.18mV/ $^\circ/\text{s}$
Variation over temperature range	< $\pm 3\%$
Nonlinearity	$\pm 1\%$ of full scale
Repeatability	$\pm 0.05\%$ 1 σ
Bias	
Setting (at +20°C)	< $\pm 0.3^\circ/\text{s}$
Variation over temperature range	< $\pm 3^\circ/\text{s}$
Instability	3 $^\circ/\text{hr}$
Repeatability	$\pm 0.03^\circ/\text{s}$ 1 σ
Angular random walk	< 0.2 $^\circ/\sqrt{\text{hr}}$
g sensitivity	< 7 $^\circ/\text{hr}/\text{g}$
Bandwidth	> 50Hz (90 $^\circ$ phase)
Noise (in-band)	< 0.35 $^\circ/\text{s}$ rms
Environment	
Operating temperature	-40°C to +75°C
Relative humidity	100%
Shock (operational)	60g (30ms, 1/2 sine)
Vibration (operational)	10g rms (20Hz to 2kHz)
Mass	< 35 gram
Electrical	
Supply voltage	$\pm 5\text{V}$, 0V
Supply current	< 50mA (each, steady state)
General	
Built In Test (BIT)	Command BIT, Alarm BIT
Start-up time	300ms
Temperature output	16.9mV/ $^\circ/\text{s}$ (0V at 25°C)
MTBF	300,000 hr
RoHS Compliance	No

Part Number	Rate Range
RRS01-01	$\pm 110^\circ/\text{s}$
RRS01-03	$\pm 300^\circ/\text{s}$
RRS01-05	$\pm 50^\circ/\text{s}$
RRS01-07	$\pm 1,500^\circ/\text{s}$
RRS01-09	$\pm 200^\circ/\text{s}$

Pin Connections

	9	Case Ground
-5V	4	8 Rate Reference
Command BIT	3	7 Rate Output
Alarm BIT	2	6 0V
+5V	1	5 Temperature

Silicon Sensing Systems Limited
 Cliftafor Road Southway
 Plymouth Devon
 PL6 6DE United Kingdom
 T: +44 (0)1752 723330
 F: +44 (0)1752 723331
 E: sales@siliconsensing.com
 W: siliconsensing.com

Silicon Sensing Systems Japan Limited
 1-10 Fuso-Cho
 Amagasaki
 Hyogo 6600891 Japan
 T: +81 (0)6 6489 5868
 F: +81 (0)6 6489 5910
 E: sales@siliconsensing.com
 W: siliconsensing.com

Specification subject to change without notice.

© Copyright 2007
 Silicon Sensing Systems Limited
 All rights reserved.
 Printed in England 09/07